

PLAN

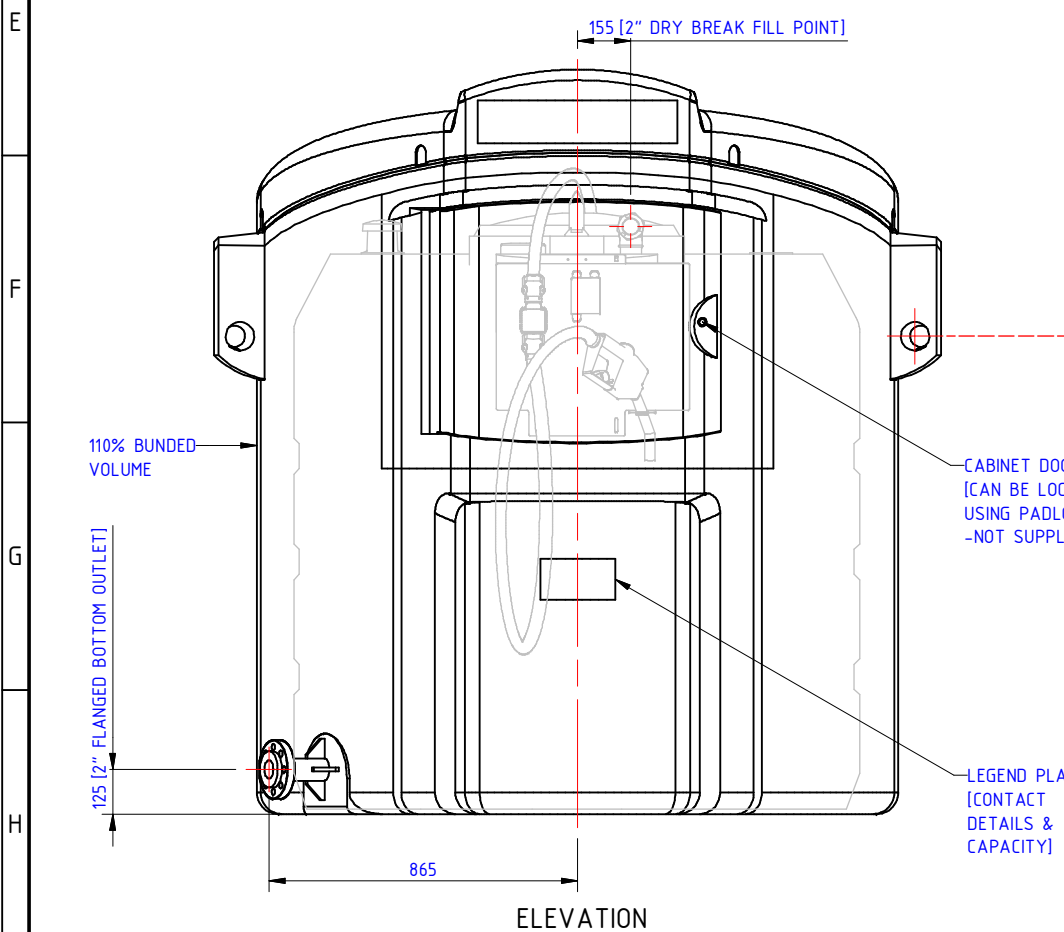

ELEVATION

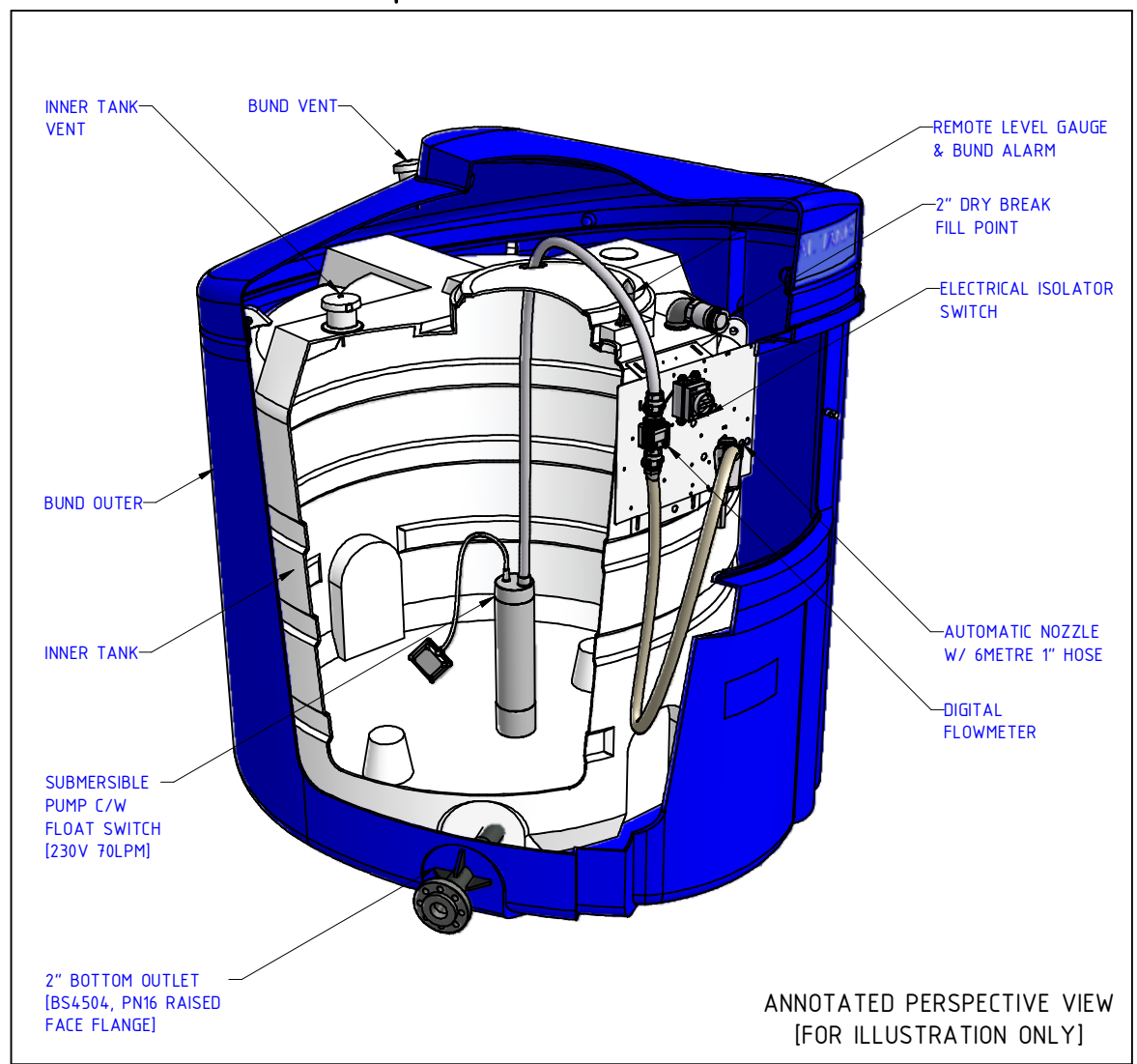

ANNOTATED PERSPECTIVE VIEW  
[FOR ILLUSTRATION ONLY]

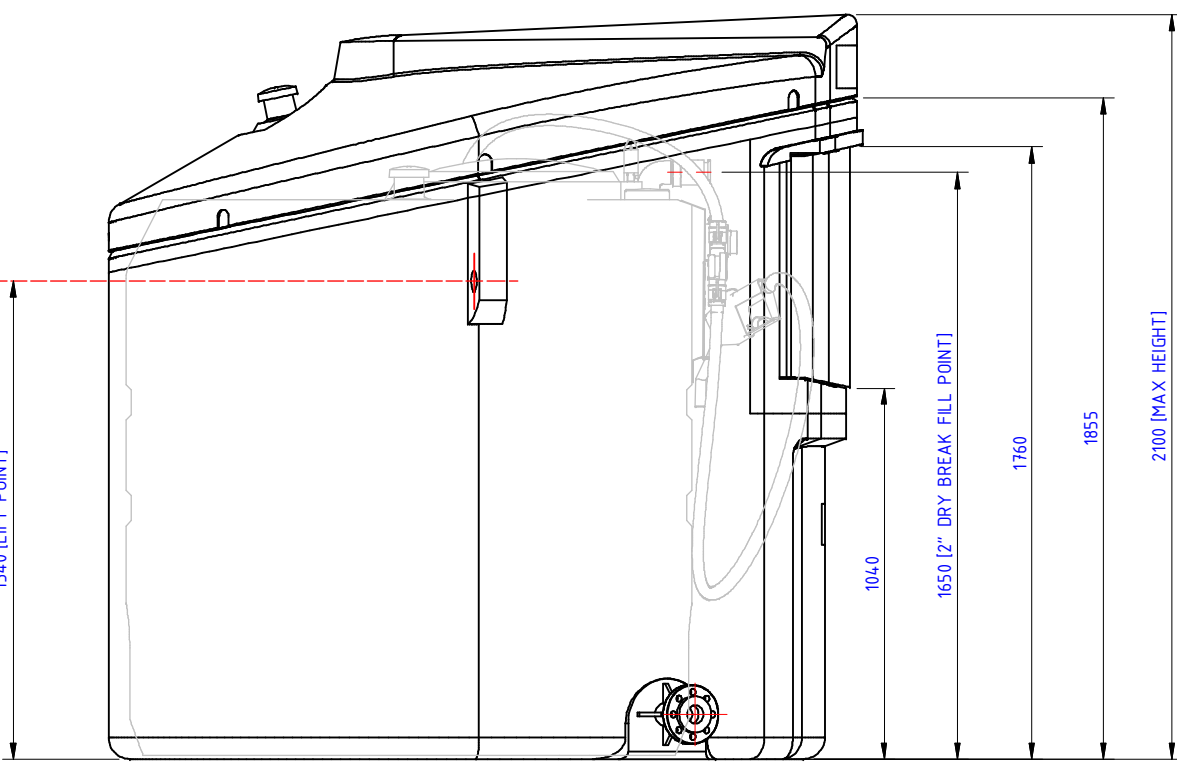

SIDE ELEVATION

THIS DRAWING IS COPYRIGHT AND IS ISSUED ON A CONDITION THAT IT IS NOT COPIED, REPRODUCED OR DISCLOSED TO A THIRD PARTY WITHOUT CONSENT IN WRITING OF BALMORAL GROUP LTD., ABERDEEN

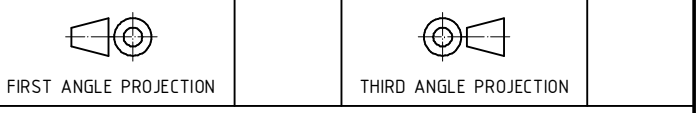

ALL DIMENSIONS IN MILLIMETRES UNLESS STATED OTHERWISE - DO NOT SCALE IF IN DOUBT - ASK

ITEM	DESCRIPTION	MATERIAL	QTY.	REMARKS

### VB2500 SUPERBLUE DISPENSING BOTTOM OUTLET

- PRODUCT FEATURES:**
- 2" DRY BREAK FILL POINT
  - 2" BOTTOM OUTLET [BS4504, PN16 RAISED FACE FLANGE]
  - SUBMERSIBLE PUMP C/W FLOAT SWITCH [230V 70LPM]
  - AUTOMATIC NOZZLE W/ 6METRE 1" HOSE
  - DIGITAL FLOWMETER
  - REMOTE LEVEL GAUGE & BUND ALARM

- MATERIALS CONTAINMENT:**
- AD-BLUE [AUS 32, DIN 70070 GRADE]

- TECHNICAL INFORMATION:**
- PRODUCT WEIGHT [EMPTY OF FLUIDS] - 230KG
  - ELECTRICAL SUPPLY - 230V, 6A.
  - LEVEL GAUGE SETTING - 1, 3, 4, 5, 8.

- GENERAL NOTES:**
- ALL ELECTRICAL WORK MUST BE CARRIED OUT BY A QUALIFIED ELECTRICIAN
  - FOLLOW INSTALLATION AND OPERATING INSTRUCTIONS

ALL MEASUREMENTS ARE FOR REFERENCE ONLY  
BALMORAL TANKS RESERVE THE RIGHT TO REVISE THEIR PRODUCT DESIGNS AT ANY TIME.

01	FIRST ISSUE	SI	BJB	BJB	28/02/08
ISSUE	MODIFICATION	BY	CHK	APV	DATE

**Global HQ**  
Balmoral Park, Loirston, Aberdeen AB12 3GY  
Tel +44 (0)1224 859000 Fax +44 (0)1224 859059  
Email group@balmoral.co.uk www.balmoral-group.com



CLIENT	PROJECT No.
BALMORAL TANKS SALES	6428

DRAWING TITLE  
VB2500 - G.A. SUPERBLUE  
BBND-SB2500-NG-SF-FM-BE

DRAWN BY	CHECKED BY	APPROVED BY	DRAWING No.
S.IRONSIDE	B.BAKEWELL	B.BAKEWELL	INVD-002

SCALE	DATE	SHEET SIZE	JOB No.
1:15	28th FEB 2008	A2	

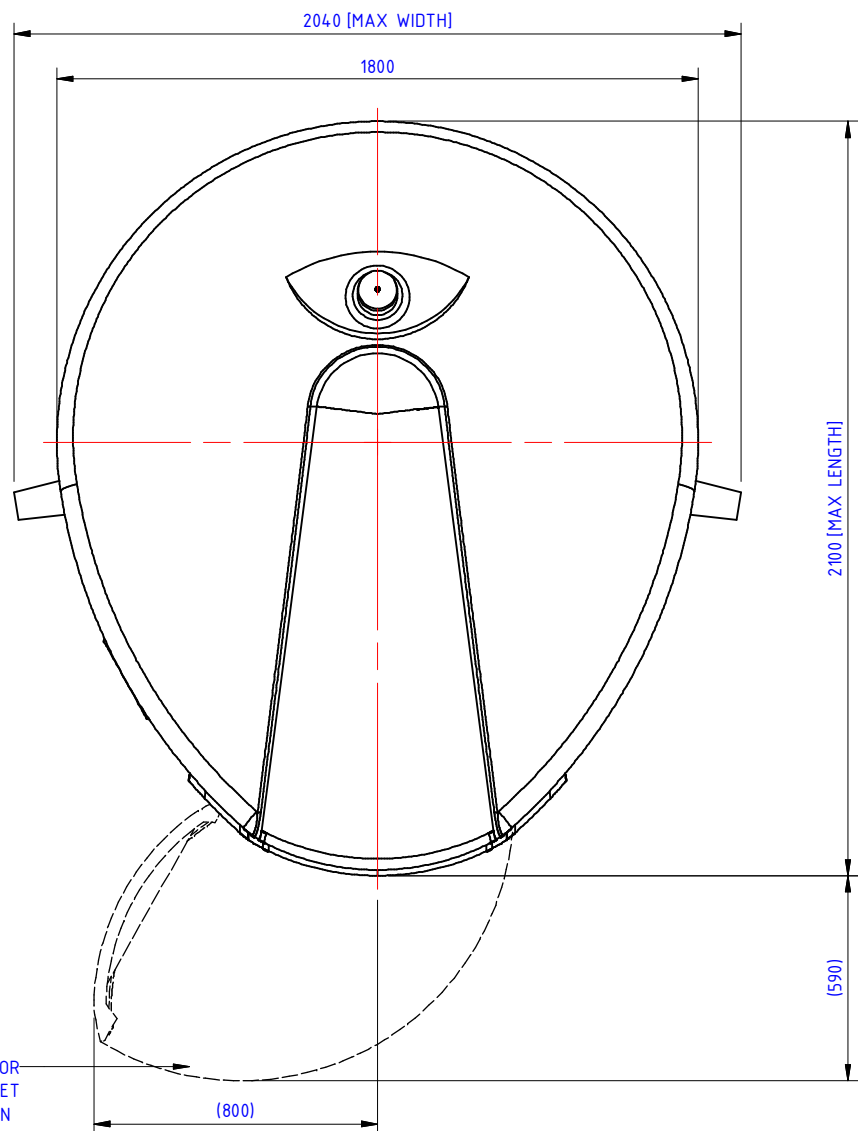

PLAN

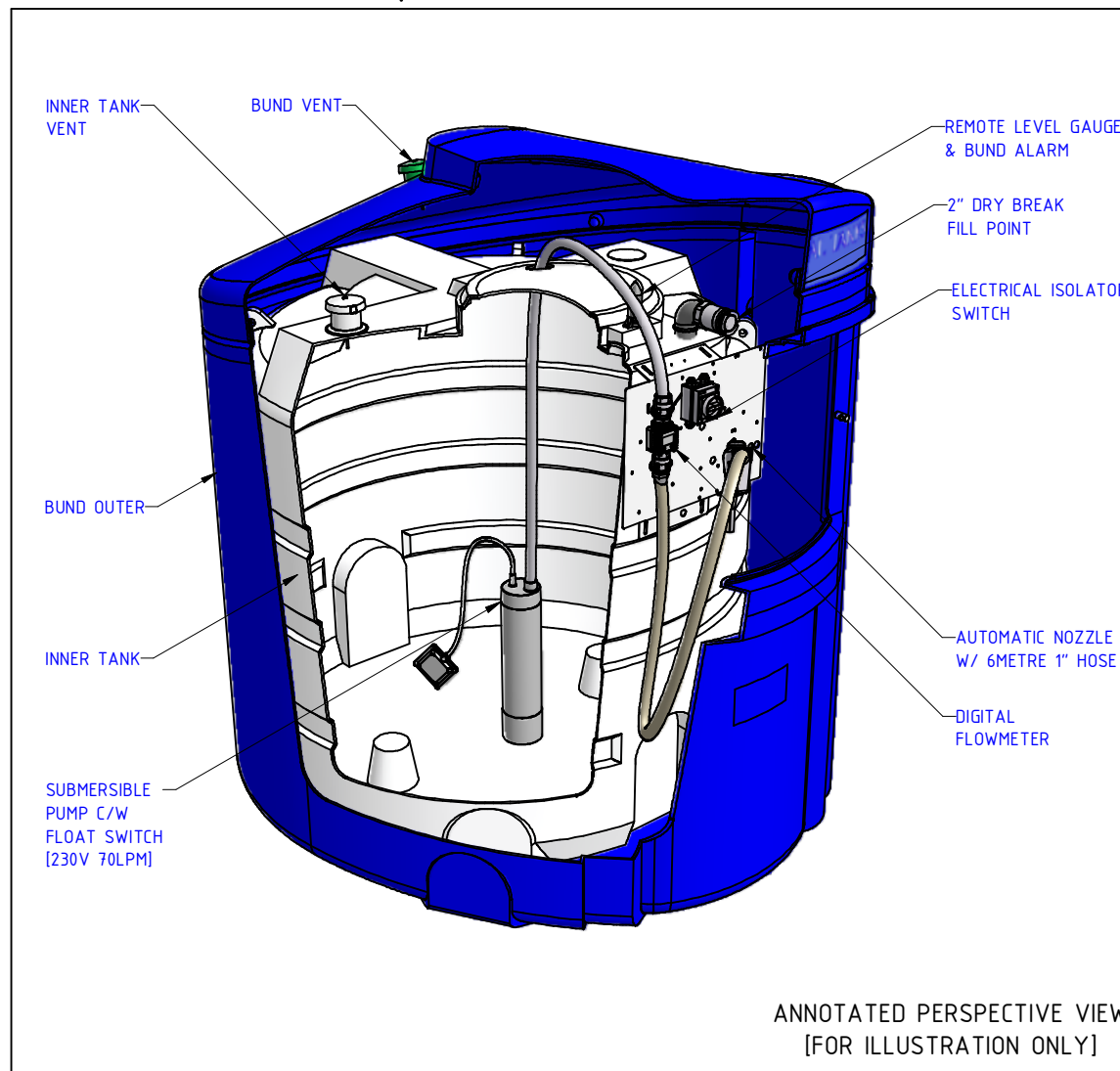

ANNOTATED PERSPECTIVE VIEW  
[FOR ILLUSTRATION ONLY]

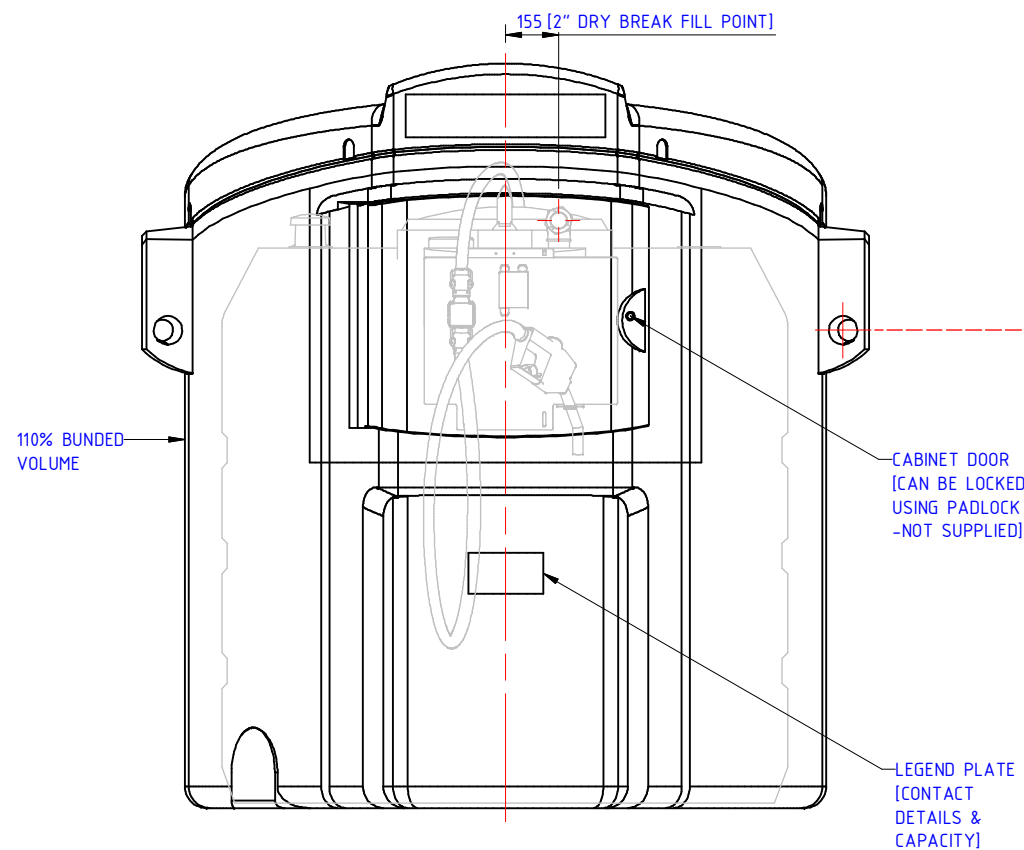

ELEVATION

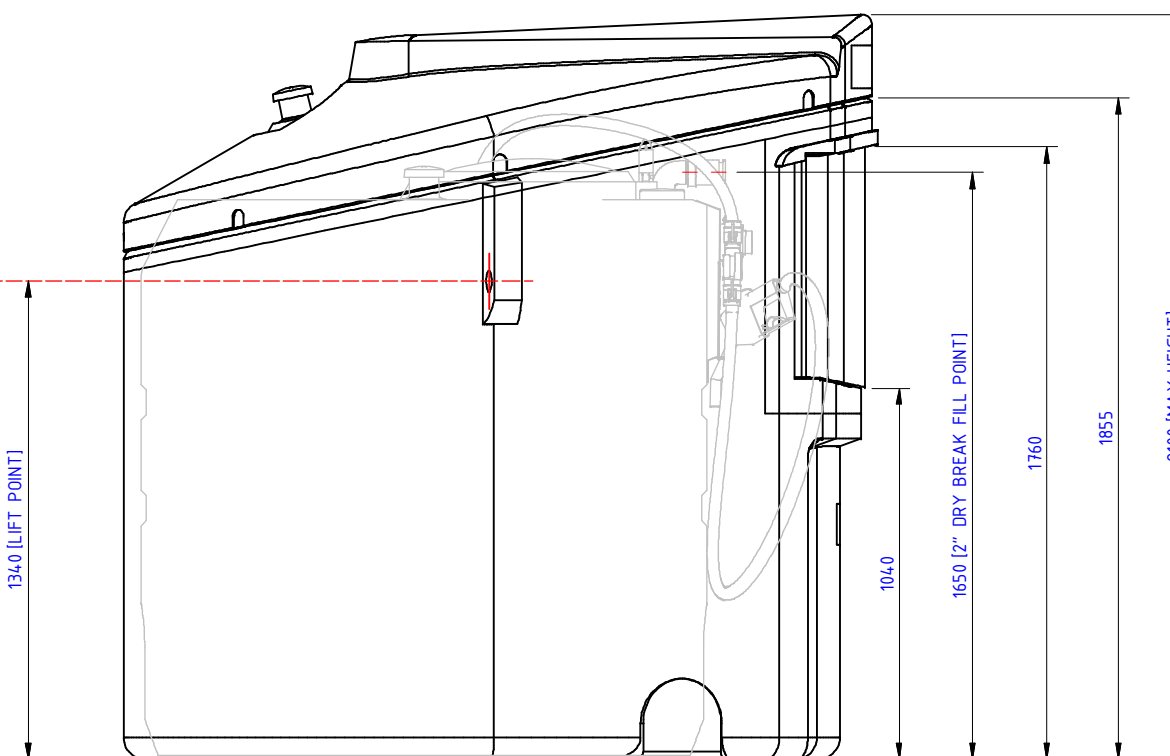

SIDE ELEVATION

THIS DRAWING IS COPYRIGHT AND IS ISSUED ON CONDITION THAT IT IS NOT COPIED, REPRODUCED OR DISCLOSED TO A THIRD PARTY WITHOUT CONSENT IN WRITING OF BALMORAL GROUP LTD., ABERDEEN

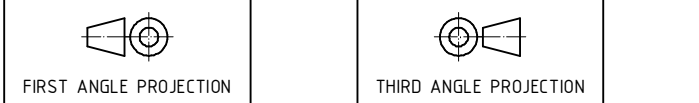

ALL DIMENSIONS IN MILLIMETRES UNLESS STATED OTHERWISE - DO NOT SCALE IF IN DOUBT - ASK

ITEM	DESCRIPTION	MATERIAL	QTY.	REMARKS
------	-------------	----------	------	---------

**VB2500 SUPERBLUE DISPENSING**

**PRODUCT FEATURES:**

- 2" DRY BREAK FILL POINT
- SUBMERSIBLE PUMP C/W FLOAT SWITCH [230V 70LPM]
- AUTOMATIC NOZZLE W/ 6METRE 1" HOSE
- DIGITAL FLOWMETER
- REMOTE LEVEL GAUGE & BUND ALARM

**MATERIALS CONTAINMENT:**

- AD-BLUE [AUS 32, DIN 70070 GRADE]

**TECHNICAL INFORMATION:**

- PRODUCT WEIGHT [EMPTY OF FLUIDS] - 225KG
- ELECTRICAL SUPPLY - 230V, 6A.
- LEVEL GAUGE SETTING - 1, 3, 4, 5, 8.

**GENERAL NOTES:**

- ALL ELECTRICAL WORK MUST BE CARRIED OUT BY A QUALIFIED ELECTRICIAN
- FOLLOW INSTALLATION AND OPERATING INSTRUCTIONS

**ALL MEASUREMENTS ARE FOR REFERENCE ONLY**  
**BALMORAL TANKS RESERVE THE RIGHT TO REVISE THEIR**  
**PRODUCT DESIGNS AT ANY TIME.**

01	FIRST ISSUE	SI	BJB	BJB	28/02/08
ISSUE	MODIFICATION	BY	CHK	APV	DATE

**Global HQ**  
Balmoral Park, Loirston, Aberdeen AB12 3GY  
Tel +44 (0)1224 859000 Fax +44 (0)1224 859059  
Email group@balmoral.co.uk www.balmoral-group.com



CLIENT	PROJECT No.
BALMORAL TANKS SALES	6428

DRAWING TITLE  
VB2500 - G.A. SUPERBLUE  
BBND-SB2500-NG-SF-FM

DRAWN BY	CHECKED BY	APPROVED BY	DRAWING No.
S.IRONSIDE	B.BAKEWELL	B.BAKEWELL	INVD-003

SCALE	DATE	SHEET SIZE	JOB No.
1:15	28th FEB 2008	A2	

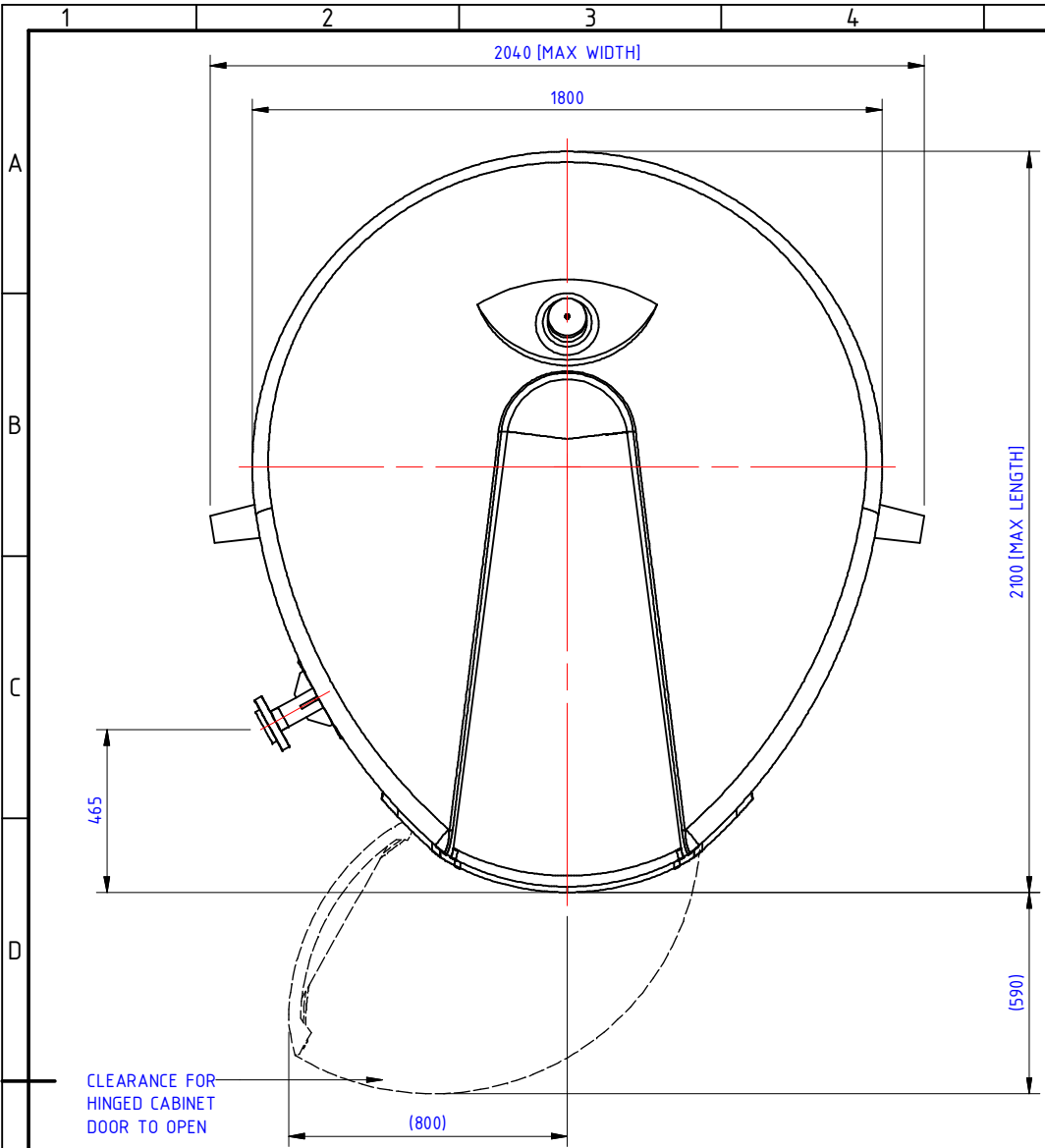

PLAN

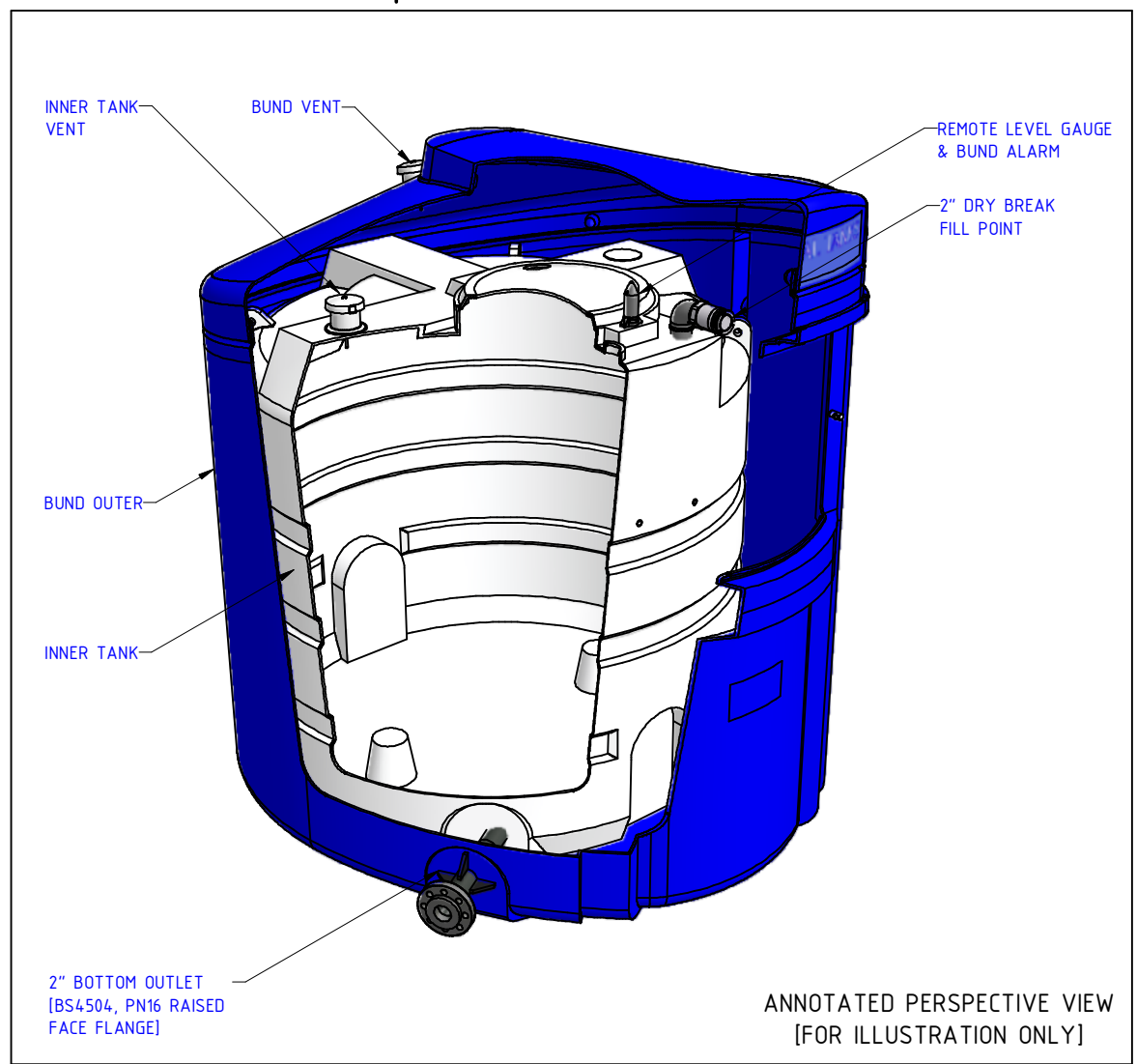

ANNOTATED PERSPECTIVE VIEW  
[FOR ILLUSTRATION ONLY]

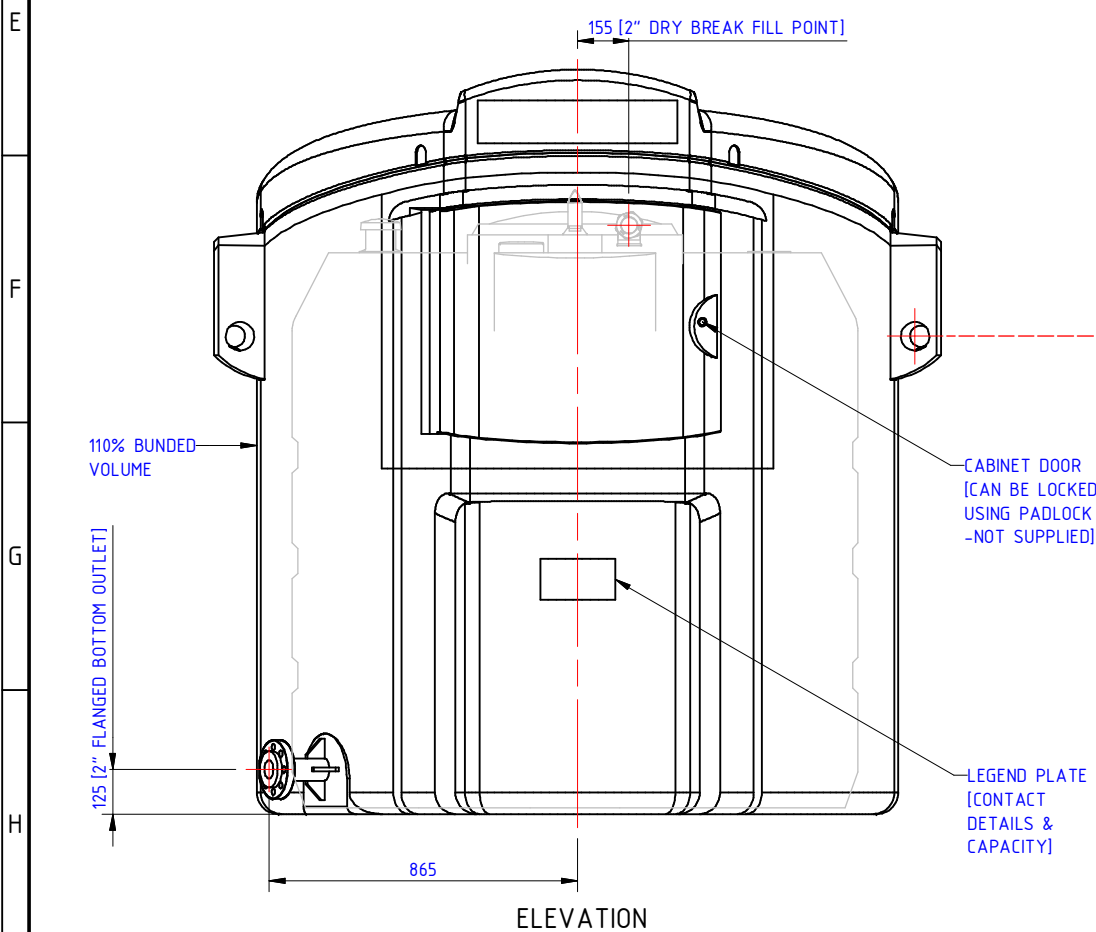

ELEVATION

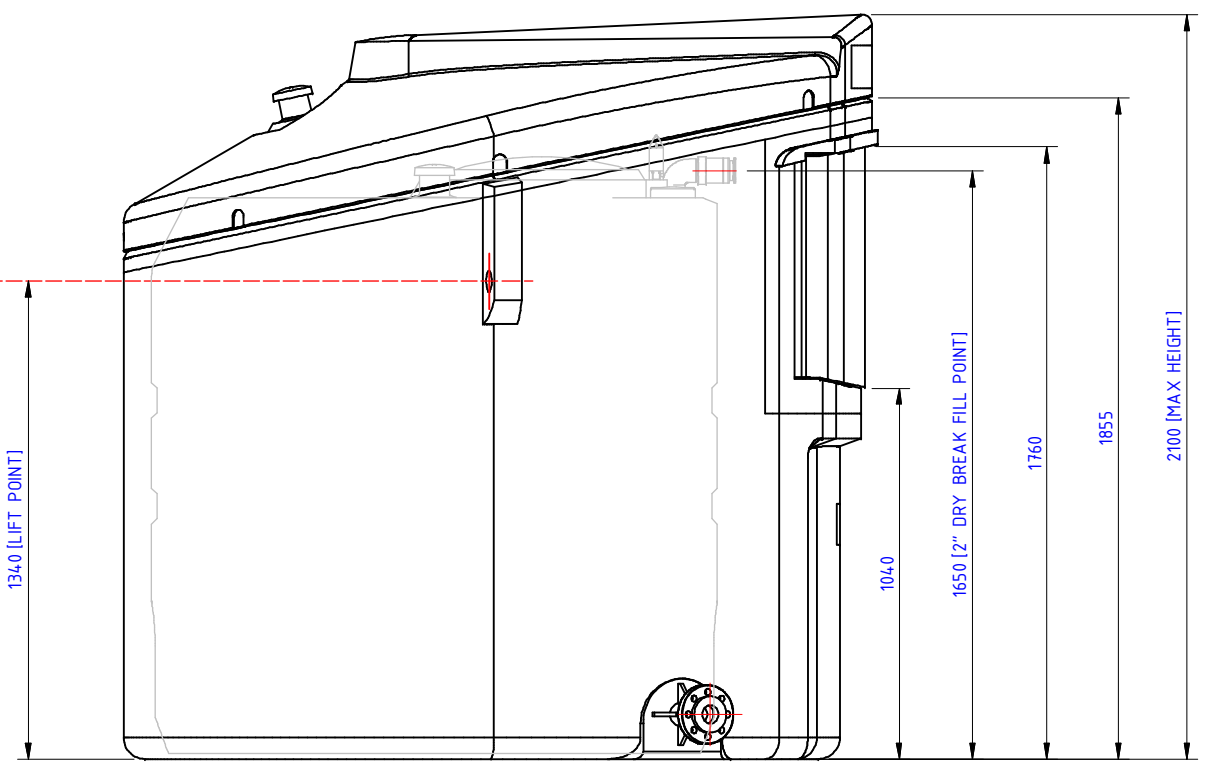

SIDE ELEVATION

THIS DRAWING IS COPYRIGHT AND IS ISSUED ON CONDITION THAT IT IS NOT COPIED, REPRODUCED OR DISCLOSED TO A THIRD PARTY WITHOUT CONSENT IN WRITING OF BALMORAL GROUP LTD., ABERDEEN

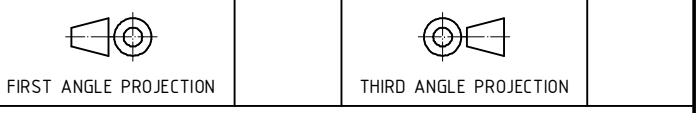

ALL DIMENSIONS IN MILLIMETRES UNLESS STATED OTHERWISE - DO NOT SCALE IF IN DOUBT - ASK

ITEM	DESCRIPTION	MATERIAL	QTY.	REMARKS
------	-------------	----------	------	---------

**VB2500 SUPERBLUE FORECOURT**

- PRODUCT FEATURES:**
- 2" DRY BREAK FILL POINT
  - 2" BOTTOM OUTLET [BS4504, PN16 RAISED FACE FLANGE]
  - REMOTE LEVEL GAUGE & BUND ALARM

- MATERIALS CONTAINMENT:**
- AD-BLUE [AUS 32, DIN 70070 GRADE]

- TECHNICAL INFORMATION:**
- PRODUCT WEIGHT [EMPTY OF FLUIDS] - 205KG
  - LEVEL GAUGE SETTING - 1, 3, 4, 5, 8.

- GENERAL NOTES:**
- ALL ELECTRICAL WORK MUST BE CARRIED OUT BY A QUALIFIED ELECTRICIAN
  - FOLLOW INSTALLATION AND OPERATING INSTRUCTIONS

**ALL MEASUREMENTS ARE FOR REFERENCE ONLY**  
**BALMORAL TANKS RESERVE THE RIGHT TO REVISE THEIR PRODUCT DESIGNS AT ANY TIME.**

01	FIRST ISSUE	SI	BJB	BJB	28/02/08
ISSUE	MODIFICATION	BY	CHK	APV	DATE

**Global HQ**  
Balmoral Park, Loirston, Aberdeen AB12 3GY  
Tel +44 (0)1224 859000 Fax +44 (0)1224 859059  
Email group@balmoral.co.uk www.balmoral-group.com

CLIENT	PROJECT No.
BALMORAL TANKS SALES	6428

DRAWING TITLE  
VB2500 - G.A. SUPERBLUE  
BBND-SB2500-NG-BE

DRAWN BY	CHECKED BY	APPROVED BY	DRAWING No.
S.IRONSIDE	B.BAKEWELL	B.BAKEWELL	INVD-004

SCALE	DATE	SHEET SIZE	JOB No.
1:15	28th FEB 2008	A2	