

# BALMORAL TANKS

## Septic tank

Installation guide and owner's manual



### Applications/uses of a septic tank

A septic tank is designed to provide what is known as primary biological treatment to crude sewage produced in a normal domestic environment. It retains solids and allows them to settle out, where they can be partially broken down by biological action so that only the remaining liquor is left to flow down the outlet drain. This liquor (normally called effluent) is then sufficiently treated to soakaway into the ground in an underground distribution system.

You may use a septic tank when your property is outwith reach of a public sewer and when suitable ground is available to provide a soakaway, but in all cases approval should be sought from the local authority Environmental Health department. It may also be necessary to obtain the consent of the Environment Agency (EA - England and Wales), the Scottish Environment Protection Agency (SEPA - Scotland) or the Environmental Protection Agency (EPA - Ireland).

If there is insufficient space to provide a soakaway system an alternative method of disposal which will provide a higher quality effluent, such as a sewage treatment plant, may be required.

### Septic tank construction

Balmoral septic tanks are produced in four sizes, ie, 2728, 3800, 4546 and 6000 litres, and are rotationally moulded in tough, polyethylene which offers a very high level of impact resistance.

### Design features

- Balmoral septic tanks are designed in accordance with British Standard Code of Practice BS6297 and are based on a two chamber design with a long flow path which ensures a high degree of settlement and sedimentation, thus providing a low level of suspended solids suitable for discharge into an underground soakaway system.
- The system of baffles ensure that no crude solids escape into the outlet drain, avoiding premature blocking of the soakaway system.
- The tanks have Ø50mm moulded-in lifting eyes for use during handling and installation (only when the tank is empty).

**Figure 1**

*Septic tank features*

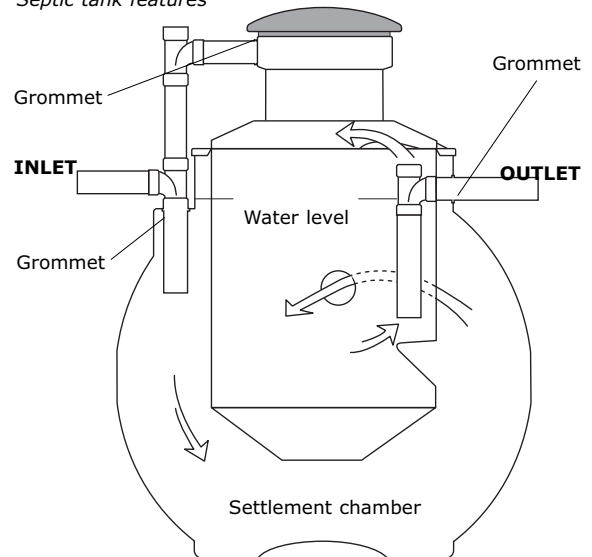

- The inlet and outlet pipework is specially designed to disperse any noxious or inflammable gases into the atmosphere through the drainage ventilation.
- The standard septic tank is designed to cater for drain invert depths of 770mm. The neck can be cut down with a panel saw to suit shallower invert depth, to a minimum of 440mm.
- The inlet pipe can be rotated by 180° to line up with the drainage lines from almost any direction.
- A fully lockable pedestrian duty manhole cover is supplied as standard to comply with statutory regulations.
- A safety grill can also be supplied as an optional item to fit across the access shaft as an additional safety feature.
- The tanks have a flat base for stability during transportation and storage prior to installation.
- Balmoral septic tanks are tested and approved by the British Board of Agrément (cert. no. 94/3021).

### Tank selection

The specified invert depth of 770mm must not be exceeded. Failure to adhere to these design parameters will render any warranty null and void and may cause severe structural damage to the tank.

Tank selection chart			
Septic tank	Stock number standard	Tank capacity litres/gallons	Pop. served at 180l person/day
BST 27	00-001-BST	2728/600	1 to 4
BST 38	00-002-BST	3800/836	5 to 10
BST 45	00-003-BST	4546/1000	11 to 14
BST 60	00-004-BST	6000/1320	15 to 22

The following sizing chart indicates the relevant tank sizes to suit from 4 to 22 persons, based on the sizing criteria in BS 6297 which is 180 litres/person/day plus 2000 litres for sludge storage.

It should be noted that the use of waste disposal units increases the daily flow substantially and for these applications the higher figure of 250 litres/day should be used.

### Siting

BS6297 states that sewage treatment works serving more than one building should be situated as far away as possible and a minimum of 25m from any habitable buildings. Some local authorities however do not deem septic tanks to be classed as a sewage treatment works, and will permit them to be installed considerably closer. 15 metres is generally regarded as the minimum distance, however this may vary from area to area. Approval for the tank position should therefore always be sought from the controlling authority at an early stage. The direction of the prevailing wind should also be taken into account when considering the siting of the tank.

The tank should not be situated close to a driveway or roadway, or anywhere there is a risk of it being subjected to additional superimposed loads. Good access must be provided for the sludge emptying tanker to within approximately 30m, and maximum head lift of 5m must be taken into consideration.

Ensure that there is room on the site to allow an excavator to operate, for the removal of soil and for delivery of concrete, gravel etc.

**Note: It is the end user's responsibility to ensure that water table/groundwater conditions do not result in water levels rising above the base of the turret of the tank.**

**Figure 2**  
Tank selection

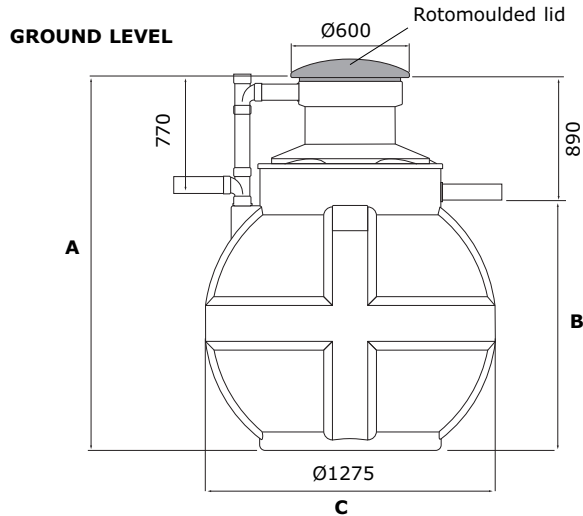

Tank dimensions (see Fig 2)			
Tank	A	B	C
BST 27	2430	1510	1860
BST 38	2640	1750	2045
BST 45	2770	1880	2165
BST 60	3005	2115	2365

All dimensions are approximate (mm).

### Installation details

#### Storage before installation

Tanks should be set on a smooth level base and securely tied or propped to prevent them from overturning and causing damage or injury.

#### Handling and craneage during transport/installation

The rotationally moulded polyethylene tanks should be handled by crane or other suitable equipment using the Ø50mm lifting eyes provided (Lift only when empty). For confirmation of product weights and dimensions, please contact Balmoral Tanks.

**Superimposed loads/protected areas**

No superimposed loads, such as vehicles, should be allowed within the protective area of the tank as shown on the diagram and chart.

If vehicular or other superimposed loads are required to come within the protected area of the tank a concrete surround or reinforced concrete slab, designed by a qualified civil/structural engineer, must be in place so that no loads are transmitted directly onto the tank (See Figure 3).

**Figure 3**  
Superimposed loads and protected areas

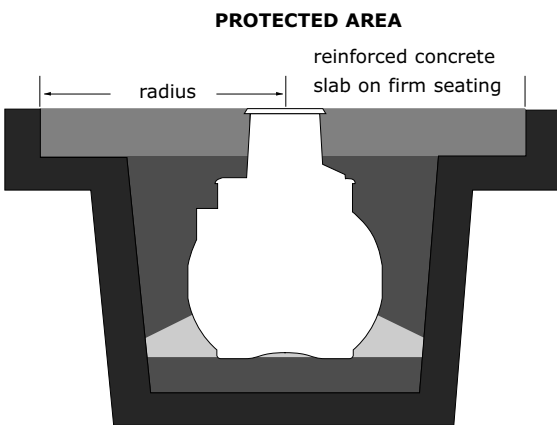

*Note: The pedestrian duty lid cannot be used where vehicular traffic is likely to come within the protected area.*

*If a reinforced concrete slab is not provided for vehicle superimposed loads then the area of the tank should be fenced off as shown in the chart below.*

Protected area around septic tank	
Septic tank stock number	Radius from centre of tank (m)
BST 27	3.0
BST 38	3.5
BST 45	3.75
BST 60	4.0

**Site installation - "Dry" ground conditions**

A site is deemed as being "dry" when at no time does ground water rise above the base of the tank. Excavation should allow for a minimum of 150mm space all round and 150mm below the tank.

Where difficult ground conditions are encountered, ie, in unstable ground or shrinking clay, etc, it will also be necessary to allow for an additional depth of  $\pm 250\text{mm}$  to be excavated below the tank to allow for hardcore and sand blinding to provide a firm base for the concrete bed.

**Installation procedure**

- Place wet concrete (slump test 30mm, strength 25N/mm) in base of excavation and grade and level to within 20mm. Lower tank carefully onto concrete and check tank is true and level.
- Fill tank with approximately 450mm water depth and place and consolidate additional concrete carefully under tank.
- Continue to fill the tank with water whilst at the same rate backfilling around the tank carefully with 12mm or 15mm dia gravel in 150mm thick layers, so that the level of the water in the tank is maintained at approximately 200mm higher than the level of backfill. This will ensure that there is equal pressure inside and outside the tank and will avoid flotation during installation.
- When the tank is full of water continue to cover the tank with a 200mm layer of gravel backfill.
- Finally, complete back filling up to ground level with earth or reinforced ground slab as required.

**Gravel specification**

Backfill material must be:

- Pea gravel or crushed aggregate of uniform particle size between 12 and 15mm.
- Chemically inert, washed clean and free of contaminants.

**Site installation - "wet" site conditions**

A site is defined as being "wet" when ground water rises above the base of the tank. At no time should water table/ground water conditions result in water levels above the base of the turret of the tank. Excavation should allow for a minimum of 200mm space all round the tank and 150mm below the tank. Where difficult ground conditions are encountered, ie in unstable ground or shrinking clay etc, it will also be necessary to allow for an additional depth (as much as deemed necessary by the supervising

engineer) to be excavated below the tank to allow for hardcore and sand blinding to provide a firm base for the concrete bed.

In poor soil conditions it is essential to make substantial provision for planking and strutting and temporary shuttering and to provide for adequate pumps to keep the excavation free from ground water at all times during the course of the work. Provision should also be made for temporary covers and fencing around the excavation site for safety.

- Place wet concrete (slump test 30mm, strength 25N/mm) in base of excavation and grade and level to within + or - 20mm.
- Lower tank carefully onto concrete and check tank is true and level.
- Fill tank with approximately 450mm water depth and place and consolidate additional concrete carefully under tank. Thereafter haunch concrete up and around the bottom 1/3 of the circumference of the tank.

- Continue to fill the tank with water and carefully place concrete around the tank in 150mm thick layers, ensuring that there are no voids remaining around the tank, and that the level of water inside the tank is maintained at a level approximately 450mm higher than that of the concrete backfill.
- **Do not use a vibrating poker.**
- Continue to fill the tank with water until it is completely full then cover the tank with 200mm thickness of concrete.
- The turret can only be surrounded in concrete after the concrete around the tank has hardened (approx 24 hrs).

Continue to backfill up to ground level (or fit reinforced concrete slab) only after concrete around tank has been allowed to harden for 24 hours. Failure to adhere strictly to the written installation instructions will render any warranty null and void.

**Figure 4**

*Septic Tank site installation*

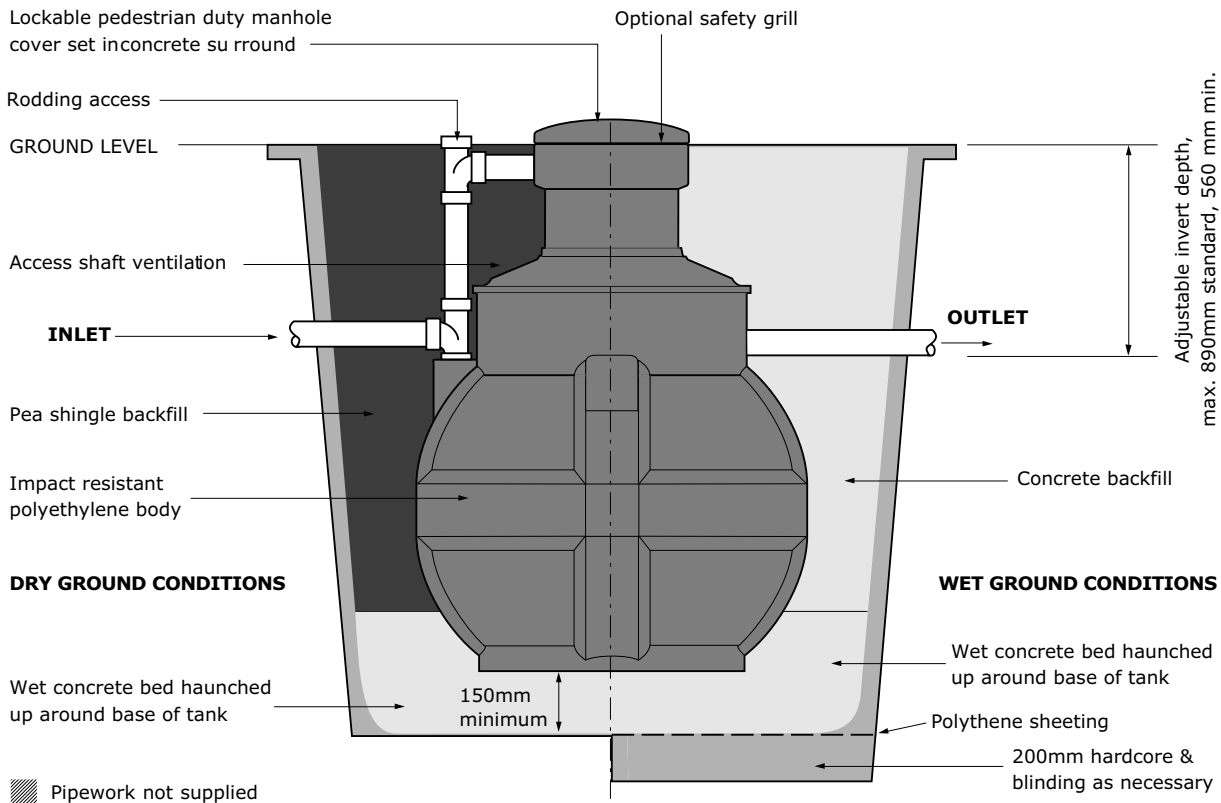

### Ventilation

A soil stack air inlet must be provided at the outlet drain of the dwelling to allow "free" air into the system. A 110mm diameter uPVC pipe connection is fitted in the access shaft to allow ventilation of the tank (as required in BS6297), without releasing any gases into the air at the tank lid(s), but allowing them to pass back up the soil vent stack. A separate vent should be provided at the head of the soak away.

### Manhole cover

The pedestrian duty manhole cover is manufactured in tough, durable rotationally moulded polyethylene and fit directly onto the neck of the tank.

### Effluent distribution drains

#### Handling

The sampling chambers can be easily unloaded and installed without special lifting or mechanical handling equipment. Avoid any impact on sharp objects.

#### Specification

The correct specification to suit site requirements should be given at time of order and the unit should be finally checked for specification onsite before installation.

It should be noted that the standard unit meets the following dimensions: (see Figure 6)

- Depth from ground level to drain invert at inlet  
1050mm
- Depth from ground level to drain invert at outlet  
1215mm
- Head drop between inlet and outlet  
165mm
- Inlet and outlets are fitted with grommets to suit pipe diameter  
OD 110mm uPVC

Special units can be supplied to order with the following options:

- Heavy duty to suit deeper invert depth (max 1.5m) with addition of extension pieces (supplied at a 600mm standard length and cut to suit the invert depth)
- For multiple inlet options (see Figure 5) the unit can be supplied without drilled holes. A 121mm diameter hole cutter should be used at the moulded drill start locations (1-5). Remove all burrs around drilled holes before fitting sealing grommets
- For reduced invert depth, the unit can be easily cut down in height using the moulded-in cutting guides for reference

Contact Balmoral Tanks for more information, if required.

#### Siting

The position of the sampling chamber should always be agreed prior to installation with the Building Control dept and the National River Authority, River Purification Board or the appropriate controlling authority. The sampling chamber should normally be situated approximately 2-3 metres downstream from the tank or treatment plant with the inlet pipe being solid (non-perforated), OD 110mm uPVC, laid to a fall of 1 in 40, and the perforated soakaway system at the outlet side laid to a maximum fall of 1 in 200. The sampling chamber can be used by more than one septic tank.

**Figure 5**  
*Inlet options*

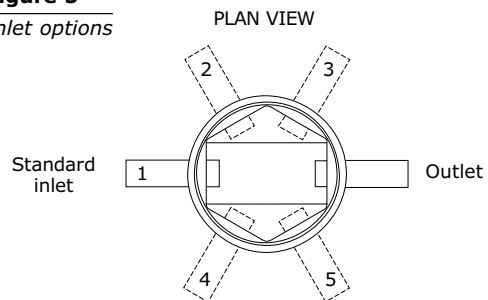

**Figure 6***Balmoral sampling chamber**Note: Inlet/outlet depths based on use with manhole cover of height 50mm*

Not to scale

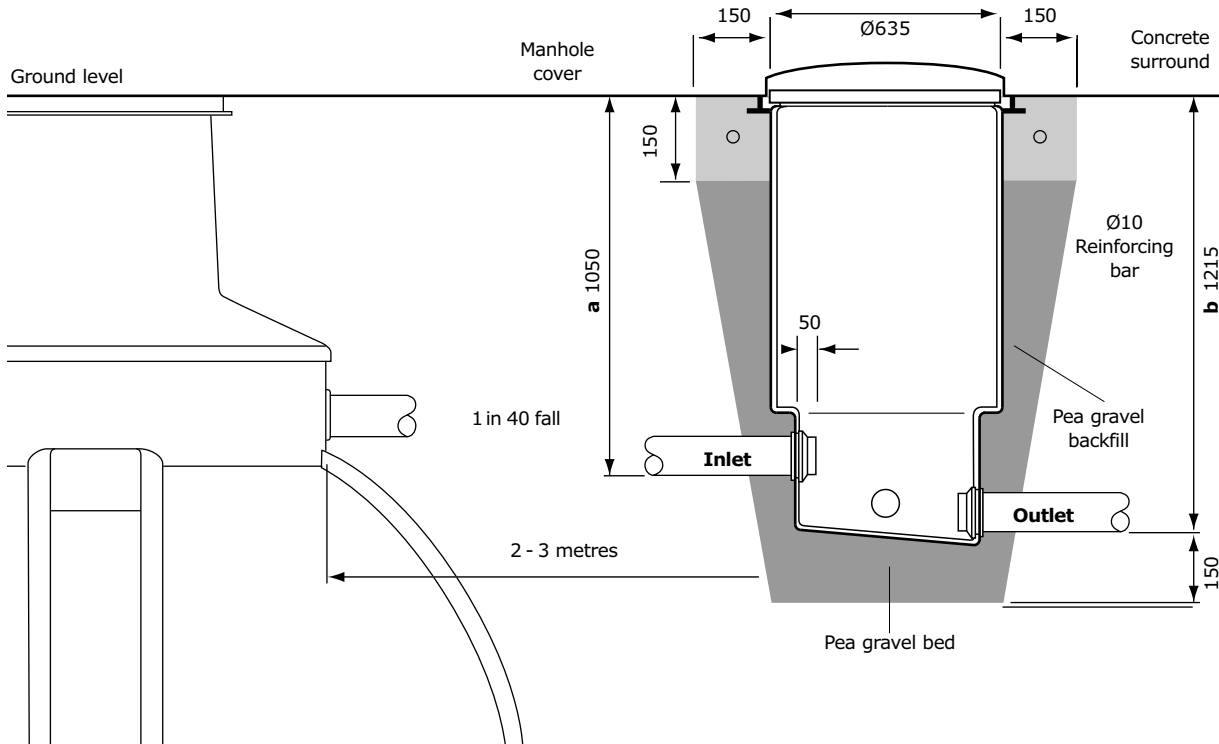
**Installation**

- The trench should be excavated along the proposed route of the drain and then enlarged at the position of the sampling chamber to allow an additional 150mm all round (ie total 900mm dia) and an additional 150mm underneath the sampling chamber
- Set the sampling chamber on a 150mm thick layer of pea gravel (12 to 15mm dia) and fit the inlet and outlet pipework into the neoprene grommets provided, so that they project 50mm into the chamber
- Check that the sampling chamber is true and level then continue to backfill carefully up around the sampling chamber with pea gravel in 150mm deep layers at the same time as the drain trench is being backfilled
- Terminate the gravel backfill 150mm below

ground level and set temporary form work to support concrete haunching around the manhole cover (minimum 150mm wide by 150mm deep). It is also recommended that a minimum of one 10mm dia steel reinforcing bar is installed within the concrete to provide additional strength (See Figure 6).

*Note: In high water or wet ground conditions it may be necessary to install with a concrete bed and backfill to prevent flotation. If in doubt consult a qualified civil or structural engineer for preferred backfill instructions.*

Please ensure that the lockable manhole cover is in position at all times to avoid accidental injury. Manhole to be sited only in areas subjected to pedestrian traffic.

### Disposal of effluent to underground strata

Septic tank effluent is normally required to be discharged into the underground strata and will not usually be permitted to flow directly into any watercourse.

In almost every case it is necessary to seek the approval of the Local Authority Building Control or Environmental Health department. It may also be necessary to obtain approval from the Environment Agency (EA - England & Wales) or Scottish Environment Protection Agency (SEPA - Scotland).

If the discharge is into porous subsoil such as gravel, sand or chalk, at a level above that of the water table in winter, a soakaway pit may be used. This consists of a pit filled with rubble or other large pieces of inert material, or unfilled but lined with dry laid bricks or precast concrete perforated rings from which the effluent may percolate into the surrounding ground. The pit should be covered by a slab incorporating an inspection cover.

In less porous subsoils a subsurface irrigation system may be practical as a more suitable alternative. It should be very carefully designed and consist of a system of field drains which should be constructed using porous or perforated pipes, laid in trenches, with a uniform gradient no steeper than 1 in 200.

To determine the length of distribution drain required, a "Percolation Test" must be carried out. The method of carrying out this test is set out in BS 6297, a description of which is given below.

#### Percolation test

Excavate a hole 300mm square to a depth of 250mm below the proposed invert level of the land drain. Where deep drains are necessary the hole should conform to this shape at the bottom but may be enlarged above the 250mm level to enable safe excavation to be carried out.

Fill the 300mm square section of the hole with water to a depth of at least 250mm and allow it to seep away overnight. Next day, refill the test section to a depth of at least 250mm and observe the time, in seconds, for the water to seep away completely.

Divide this time by the depth in millimetres of water placed in the hole to establish the average time required for the water to drop 1mm. Take care when making the test to avoid abnormal weather conditions such as severe frost or drought.

The percolation test should consist of three measurements carried out as above, taking an average of the three results. In the event of any of the measurements in a test being 50% or more above or below the average, make a further three measurements and calculate a further average. Unless an average value of  $V_p \leq 24$  s/mm or less is obtained (in which case no further tests are needed), make further tests on a minimum of three different locations on the route of a land drain, or at least three tests on separate days on the site proposed for a soakaway.

Where deep excavations are necessary a modified test procedure may be adopted using a 300mm earth auger. Bore the test hole vertically to the appropriate depth taking care to remove all loose debris. Make water level observations referring to a fixed datum, using a dip stick or some suitable alternative water level indicator.

The value found in this way is called the percolation value ( $V_p$  in seconds) of the soil and can be used to determine the area of drainage trench floors required to disperse effluents. If the percolation value exceeds 140 seconds the soil is not suitable for drain fields. From 140s to 100s (about 10 to 7 hours to fall 250mm), under drains are desirable, and advice should be sought from the local authority.

*Note: If the level of the water table rises in winter to within 1 metre of the proposed invert of the distribution system, it is not advisable to use subsurface irrigation.*

### Effluent distribution drains

The first 3m length of drain from the septic tank should be solid drain and laid at a good fall - eg 1:40, and should terminate at a sampling chamber built to water authority requirements. Thereafter the distribution drain should be laid out in either herringbone or closed loop system, either level or not exceeding 1 in 200 fall. Clay or rigid uPVC perforated pipe should be used at a minimum depth of 500mm. The drain should be laid in a bed of 38-50mm diameter hardcore or gravel with 50mm cover on top. Lay 500 gauge polythene on top of the gravel and backfill with soil.

**Figure 7**

Section through typical distribution drain

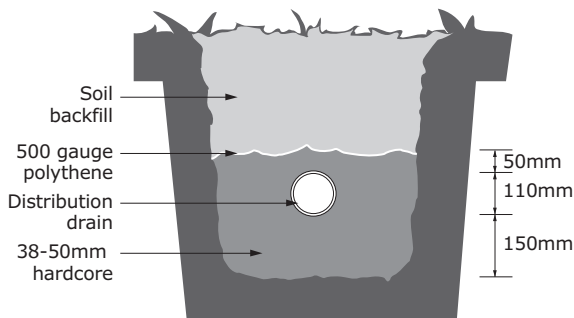

### Calculation methods

The floor area of the subsurface drainage trench is calculated using the following formula:

$$At = P \times Vp \times 0.25$$

Where:

- At** = area of trench in square metres  
**P** = number of persons served by the septic tank  
**Vp** = percolation value in seconds as described above  
**0.25** = constant

*Note: For effluents which have received secondary treatment followed by a settlement tank (normally 30 SS and 20 BOD), this area can be reduced by 20%.*

ie:

$$At = P \times Vp \times 0.20$$

The area determined is used to calculate the floor area of the drainage trench and therefore the length of distribution drain, or alternatively the floor area of one or more shallow soakaways.

An example using this formula is shown below:

$$\begin{aligned} Vp &= 12 \text{ seconds} \\ P &= 5 \text{ persons} \\ At &= 5 \times 12 \times 0.25 \\ At &= 15\text{m}^2 \text{ drain trench } 0.6\text{m wide} \\ &= 25 \text{ lineal metres} \end{aligned}$$

Further examples are shown in the chart below - assuming the base of the trench is 600mm wide the length of drain will be:

Soak away/drain sizing chart						
Tank capacity (litres)	2720	3800	4500	6000	7500	9000
Number of persons served	4	10	14	22	30	39
Vp (sec/mm)						
5	8.33	20.83	29.17	45.83	62.50	81.25
10	16.66	41.67	58.33	91.67	125.00	162.50
20	33.32	83.33	116.67	183.33	250.00	325.00
30	50.00	125.00	175.00	275.00	375.00	487.50
40	66.64	166.66	233.33	366.67	500.00	650.00
50	83.33	208.33	291.67	458.33	625.00	812.50

As the chart indicates, for larger populations where the soil is poor it may well be more economic to look at an alternative system for effluent disposal such as installing a sewage treatment plant and taking the effluent directly to a watercourse - or pumping the effluent to a more suitable area of ground.

### Notes

- 1 The local authority and Environment Agency should always be consulted and they may require the test to be carried out by a specialist consulting engineer.

2 The information herein is for guidance only and can form no part of any contractual agreement either with Balmoral Group Ltd or any third parties. Balmoral Group Ltd can accept no responsibility for any assumptions or agreements made as a result of this information.

**Figure 8**  
Section through a raised percolation trench

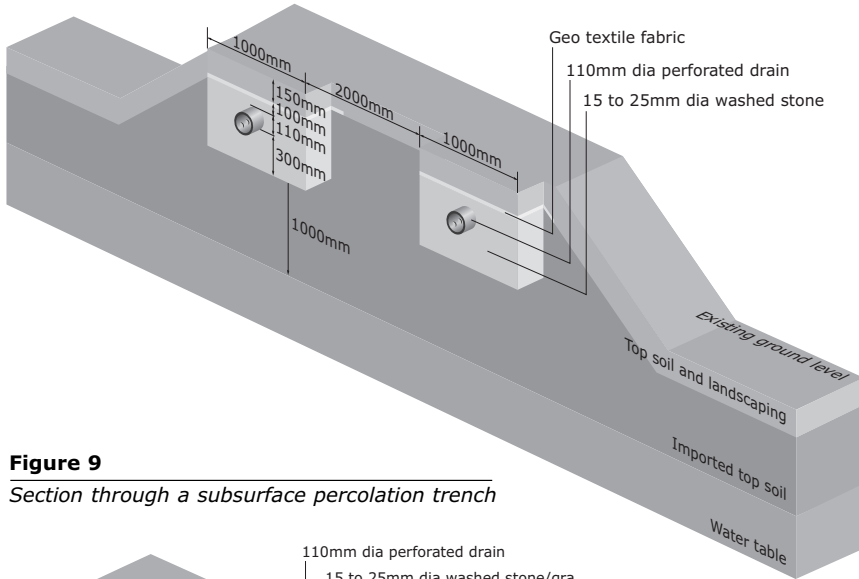

**Figure 9**  
Section through a subsurface percolation trench

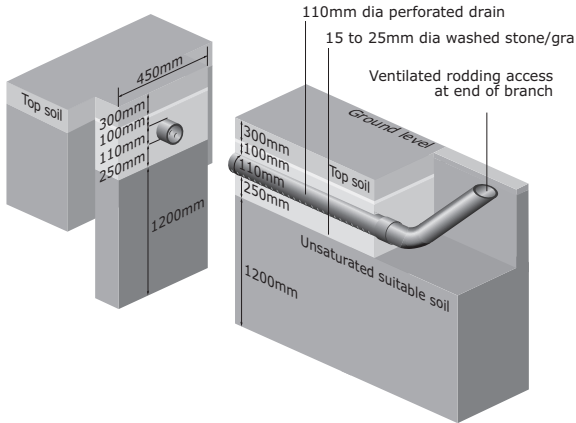

**Balmoral Site Services**

Balmoral Site Services offers a nationwide service to cover all aspects of maintenance on the company's environmental product range. Services can be tailored to suit your requirements from basic annual maintenance contracts to on-going support and advice from legislative bodies.

Balmoral Site Services benefits:

- Full support from the UK's largest manufacturer
- National coverage
- Fully qualified and experienced staff
- Advice and support on installation and maintenance
- Advice and support on environmental & local authority guidelines and legislation
- A cost effective guarantee to ensure your tank always meets effluent standards - preventing pollution of rivers and watercourses

**Advisory service and maintenance contracts**

For technical advice or to arrange a visit by one of Balmoral's technical representatives, please contact Balmoral Site Services on the following numbers:

**Product registration and maintenance**

Tel +44 (0)1224 859000  
Fax +44 (0)1224 859123  
Email tanks@balmoral.co.uk

Plant purchase date:

Plant commission date:

Comments about installation (with recommendations of remedial work): \_\_\_\_\_

**Maintenance log**

<b>Service date</b>	<b>Maintenance undertaken</b> (Service/call out/desludge)	<b>Major spares used</b> (Warranty/chargeable)	<b>Signature</b> (Balmoral engineer or authorised agent)
Date of desludge:		Name of waste disposal co:	Amount of sludge removed:
Date of desludge:		Name of waste disposal co:	Amount of sludge removed:
Date of desludge:		Name of waste disposal co:	Amount of sludge removed:
Date of desludge:		Name of waste disposal co:	Amount of sludge removed:
Date of desludge:		Name of waste disposal co:	Amount of sludge removed:
Date of desludge:		Name of waste disposal co:	Amount of sludge removed:
Date of desludge:		Name of waste disposal co:	Amount of sludge removed:
Date of desludge:		Name of waste disposal co:	Amount of sludge removed:
Date of desludge:		Name of waste disposal co:	Amount of sludge removed:
Date of desludge:		Name of waste disposal co:	Amount of sludge removed:
Date of desludge:		Name of waste disposal co:	Amount of sludge removed:

# BALMORAL TANKS

**Head Office & Factories**

Balmoral Park, Loirston, Aberdeen AB12 3GY, Scotland

Tel+44 (0)1224 859000 | Fax +44 (0)1224 859123 | E-mail tanks@balmoral.co.uk | www.balmoraltanks.com

